

Step 1

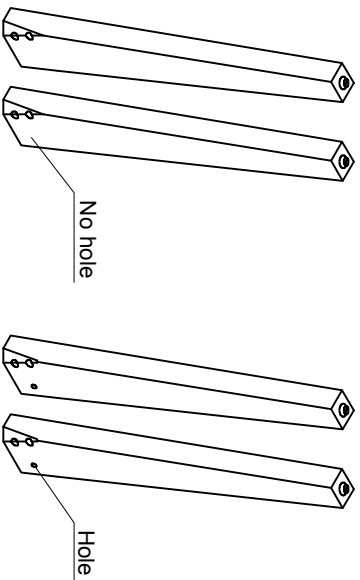

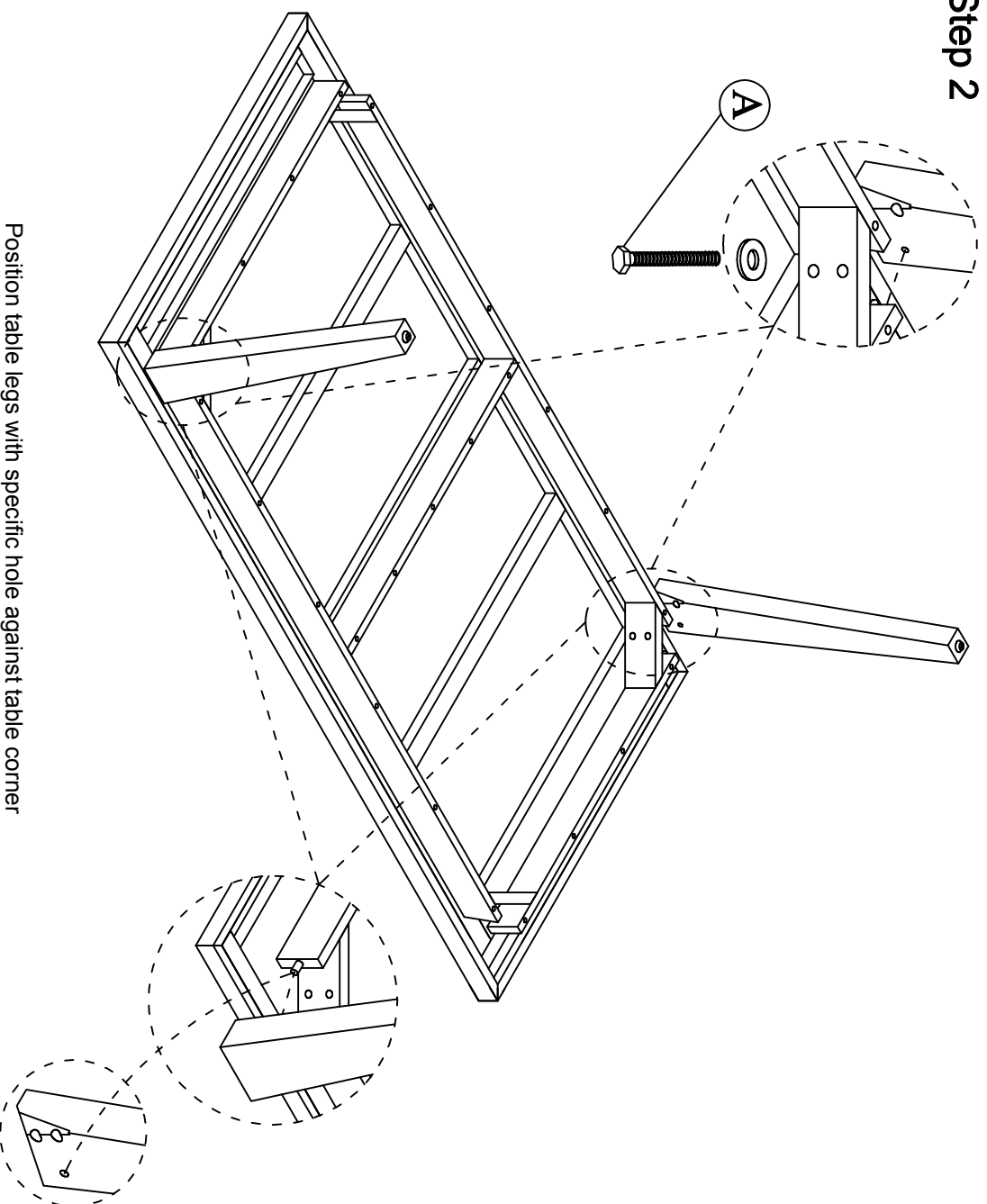

Warning: There are two different legs used for this table
 - With specific holes on one side
 - Without hole on side

Step 2



Position table legs with specific hole against table corner blocks and machining dowel pins at the end of table aprons

<p>Parts List</p>	<p>A</p>		<p>Bolt M10x60mm</p>		<p>8PCS</p>	<p>B</p>		<p>Key wrench</p>	<p>1PC</p>
--------------------------	-----------------	---	----------------------	--	-------------	-----------------	---	-------------------	------------

Step 3

Position table legs without specific holes against the screw holes on the other table corner blocks of the aprons

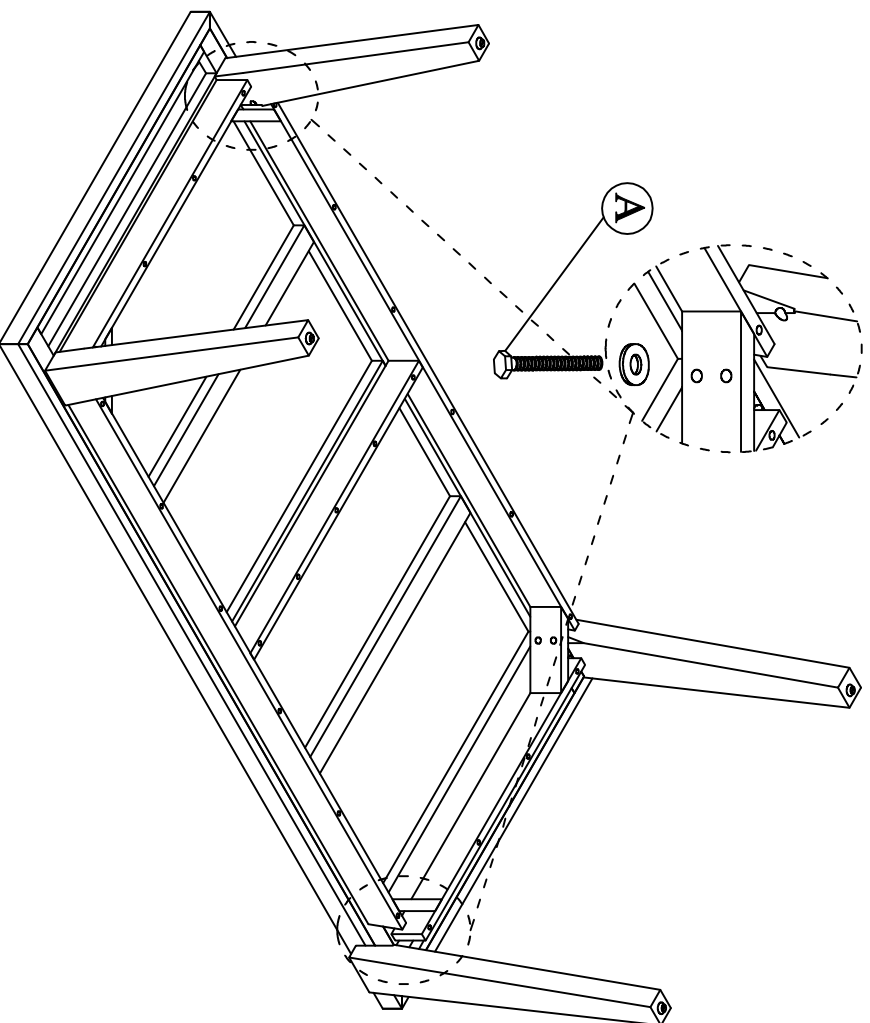

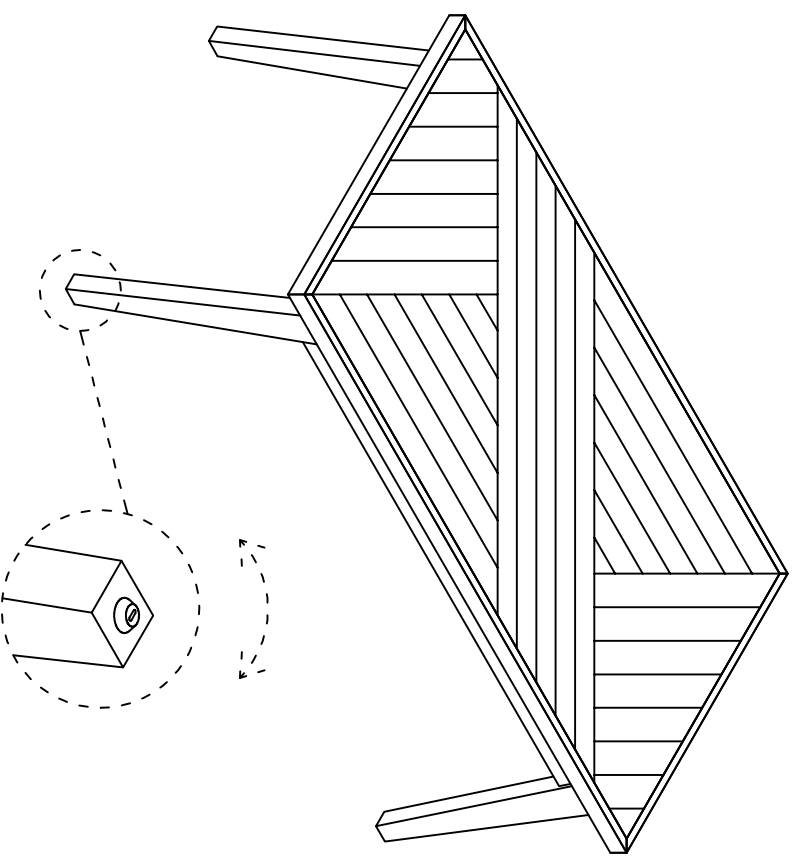

After everything is in place, secure the bolts and washers

Picture



Please use the adjustable knobs to level the table

<p>Parts List</p>	<p>A</p>	  <p>Bolt M10x60mm</p>	<p>8PCS</p>	<p>B</p>	 <p>Key wrench</p>	<p>1PC</p>
--------------------------	-----------------	---	--------------------	-----------------	---	-------------------