

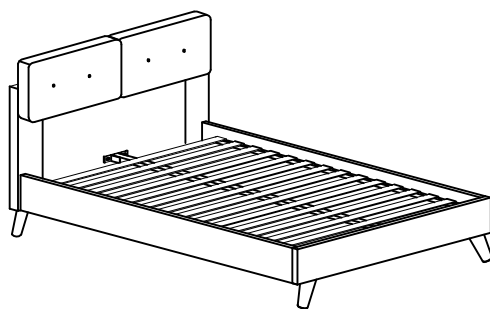









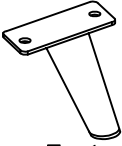

Assembly Instruction Brooklyn Queen/King Bed

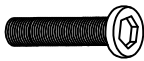

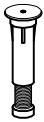

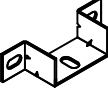
Tools Needed
2 person build



BED FITTINGS

 Feet	 Gold Bolts (m8*20)	 Washers (m8)	 Allen Key (M5)	 Footboard Wood	 Gold Bolt (m8*55)	 Spring Washers (m8)
① X 4	② X 8	③ X 22	④ X 1	⑤ X 2	⑥ X 6	⑦ X 10
 Plastic Support legs	 Gold Bolts (m8*18)	 Bolts (m8*40)	 Brackets	 Bolts (m8*20)	 Screws (m8*32)	 Screws (m8*38)
⑧ X 2	⑨ X 8	⑩ X 2	⑪ X 2	⑫ X 6	⑬ X 42	⑭ X 4

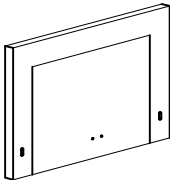
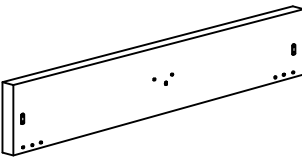
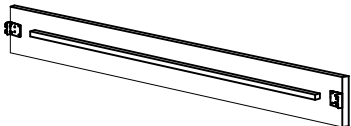
PART LIST

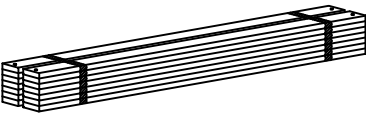
 Headboard	 Footboard	 Side Rails
A X 1	B X 1	C X 2
 Centre Rail	 Slats	
D X 1	E X 1	

Step 1

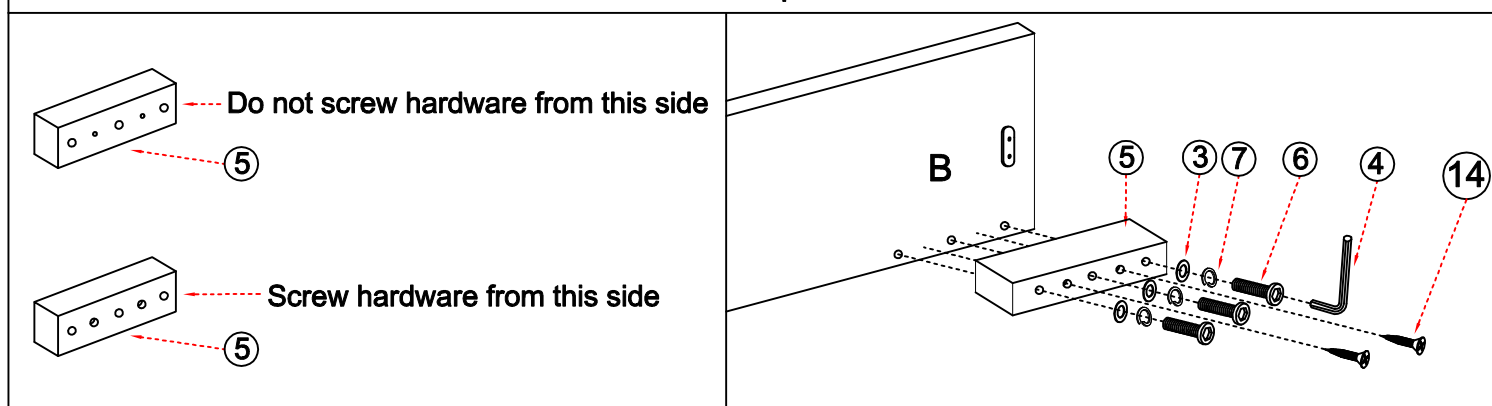

Step 2

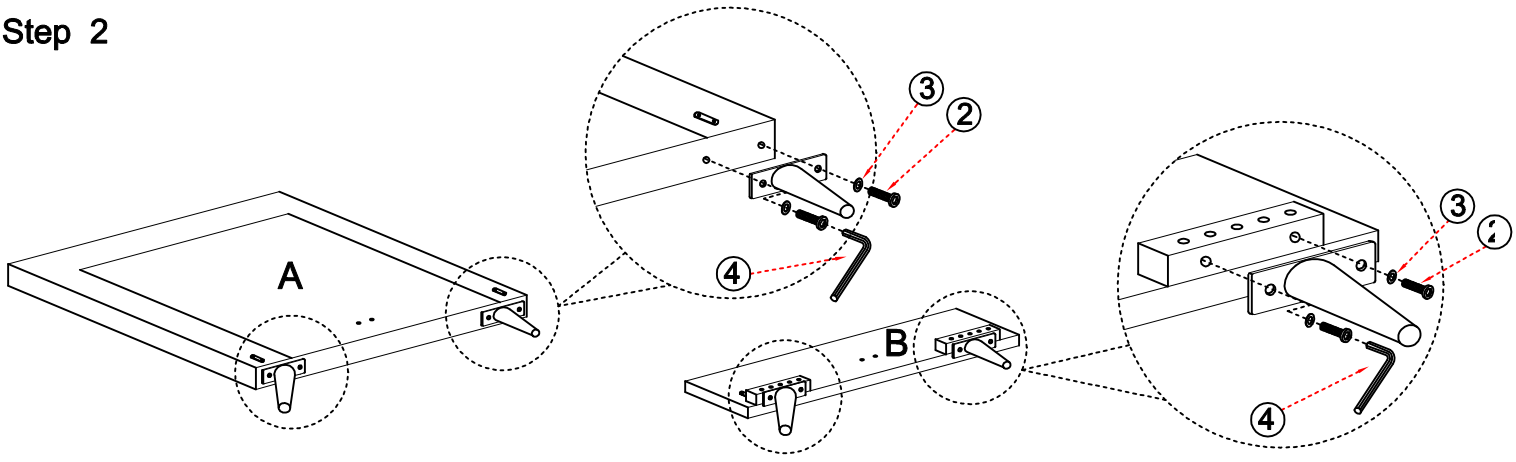

Step 3

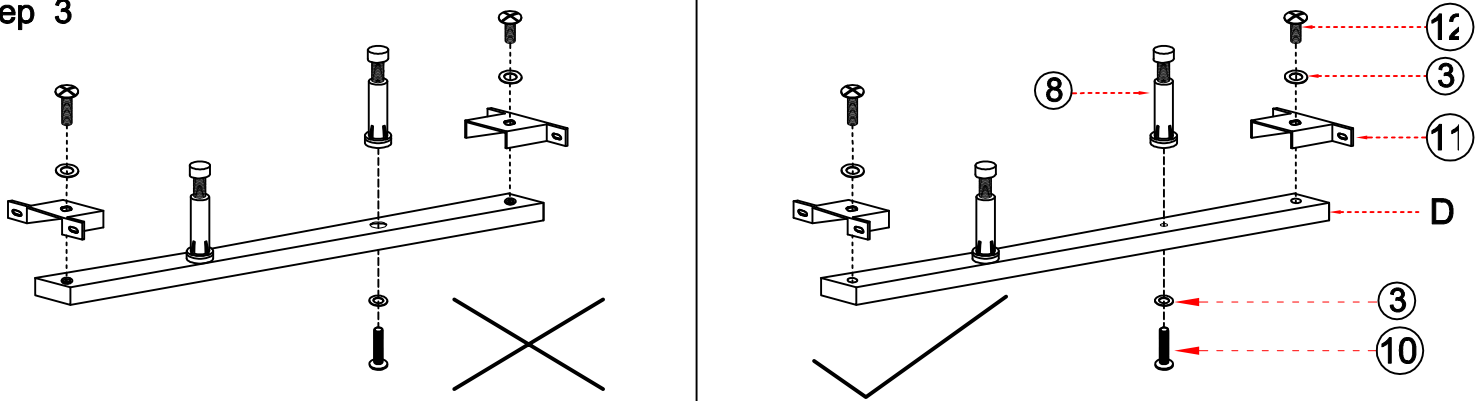

Step 4

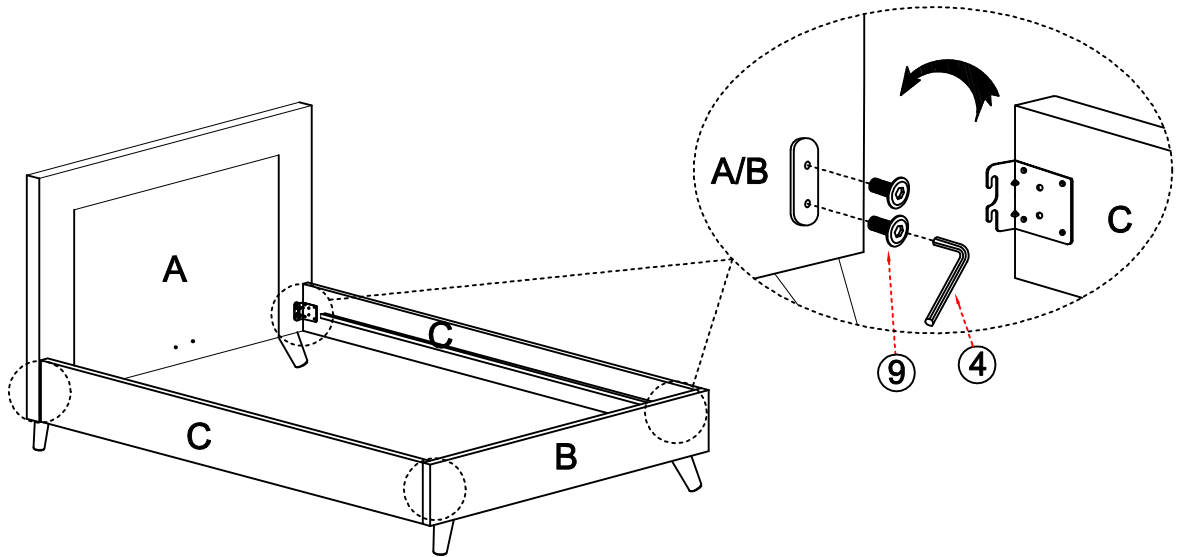

Step 5

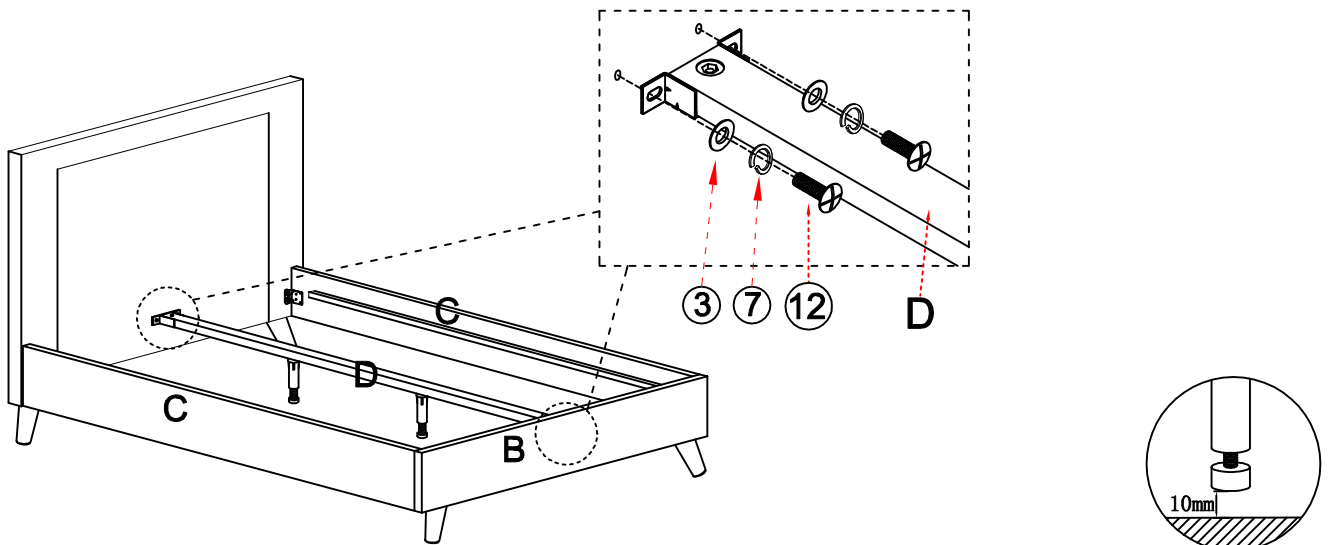

Step 6

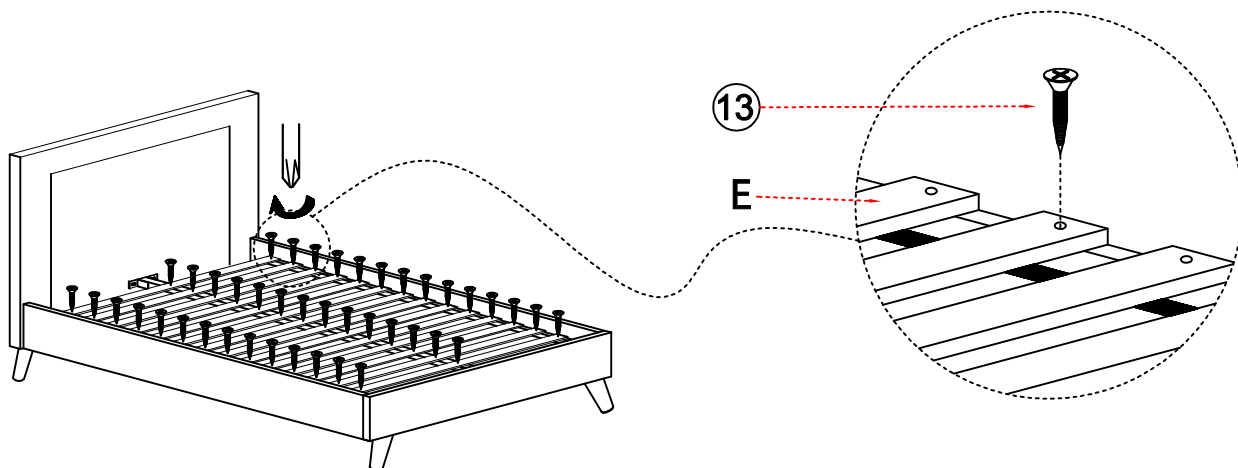

Step 7

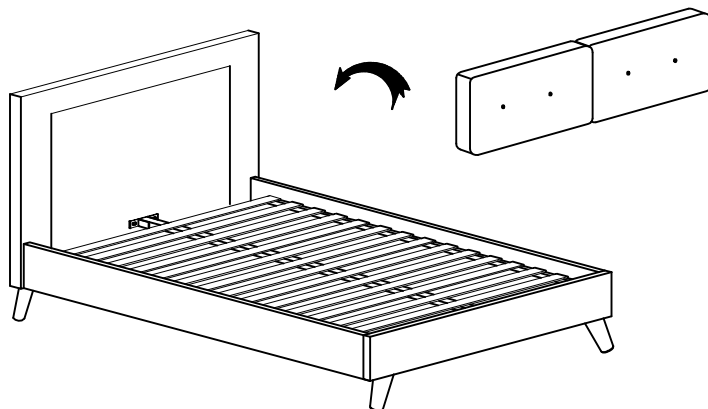

Step 8

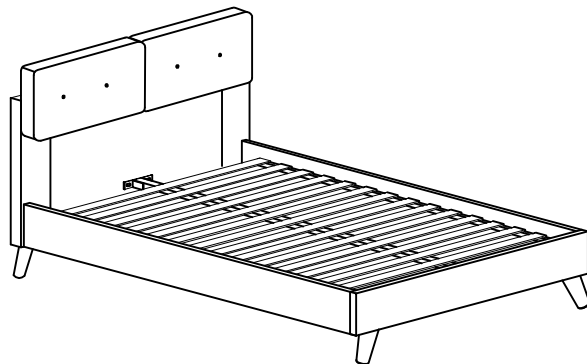

REMARK : ONCE BED IS ASSEMBLED, **DO NOT** SIT, STAND OR APPLY WEIGHT DIRECTLY TO SLATS UNLESS MATTRESS IS IN PLACE.